

# Equilibria and Dynamics of Toluene and Trichloroethylene onto Activated Carbon Fiber

Jee-Won Park\* · Young-Whan Lee · Dae-Ki Choi · Sang-Soon Lee

*Environmental & Process Technology Div.*

*Korea Institute of Science and Technology\**

*Department of Applied Chemistry, Dongduk Women's University*

## 요 약

**ABSTRACT :** Adsorption dynamics for toluene and trichloroethylene with an isothermal fixed bed of activated carbon fiber were investigated. Equilibrium isotherms were measured by a static method for toluene and trichloroethylene onto activated carbon fiber at temperatures of 298, 323, and 348 K and pressure up to 3 kPa for toluene and 6 kPa for trichloroethylene, respectively. These results were correlated by the Toth equation. And dynamic experiments in an isothermal condition of 298 K were examined. Breakthrough curves reflected the effects of the experimental variables such as partial pressures for adsorbate and interstitial bulk velocities of gas flow. To present the column dynamics, a dynamic model based on the linear driving force (LDF) mass transfer model was applied.

## INTRODUCTION

Volatile organic compounds (VOCs) are one of the most common pollutants emitted by many industrial chemical plants such as coating, spray painting, dyeing, and polymer processing. Because of their high vapor pressure, VOCs can evaporate easily into atmosphere and have been implicated as a principal factor to photochemical smog, which can cause haze, damage to animal and respiratory problems to human. In that VOCs are major contributors in air pollutant, control of VOCs emission is a principal concern of the industries' commitment toward the environment<sup>1)</sup>.

There are many different techniques available to VOCs controlling, particularly adsorption is the most effective method, which is VOCs are removed from the bulk gas by physical adsorption onto the

surface adsorbent. The adsorption capacity and characteristic of adsorbent selected for the given VOCs are often represented by an adsorption isotherm of the amount of VOCs adsorbed (adsorbate) to the equilibrium pressure (concentration) and constant temperature.

To date, activated carbon is one of very useful adsorbents for VOCs control. However, some disadvantages for the application of activated carbon include its flammability, difficulty in regenerating high-boiling point solvents and required humidity control [2]. On the positive side, activated carbon fiber has uniform size and dimension, higher adsorption capacity, faster adsorption and desorption rates than activated carbon, and ease of handling<sup>3-4)</sup>. These features obtain adsorptive system size reduction and added adsorbed vapor selectivity. In these respects, activated carbon fiber, as alternative

to activated carbon inefficiencies, is an excellent micropore adsorbent.

In this study, we focused our attention on investigating the equilibrium of toluene and trichloroethylene and the adsorption dynamics in column for activated carbon fiber. The adsorbates selected in this work, toluene and trichloroethylene are ubiquitous in many industrial fields. Furthermore, it has been reported that these aromatic hydrocarbons are toxic, and accordingly cause diseases of the nervous system and sterility<sup>9</sup>.

## EXPERIMENTAL

### Materials.

Pitch-based activated carbon fiber, Nano-10 (Nanotechnics Co., Korea)<sup>6</sup>, was used as the adsorbent. Generally, activated carbon fiber derived from raw materials as various as pitch, cellulose, PAN, and phenol resins. The adsorption behaviors of the activated carbon fiber depend on the kinds of precursors, e. g., the pitch-based activated carbon fiber has the highest carbon content and is suitable for organic solvent controlling. Using the adsorption of nitrogen at 77 K, the BET specific area for Nano-10 was measured by an automatic sorption analyzer (Quantachrom Autosorb-1). Nano-10 has a BET surface area of  $1453 \text{ m}^2 \text{ g}^{-1}$ , total pore volume of  $0.4096 \text{ cm}^3 \text{ g}^{-1}$  and mean pore diameter of  $22 \text{ \AA}$ . Prior to the experiments, the adsorbent was kept in a drying vacuum oven at 423 K for more than 12 h to remove impurities.

### Isotherm measurement.

The isotherm equilibria were measured by the adsorption equilibrium apparatus based on the static volumetric method in Figure 1. The total amount of vapor introduced and recovered in the system after equilibrium is determined and recovered by appropriate

pressure, volume and temperature measurements. During the experiment, the adsorbent cell was kept in a water bath and maintained by a refrigeration circulator with a precision of  $\pm 0.02 \text{ K}$ . Prior to the introduction in the adsorbent cell, the mass of the adsorbent was determined with an accuracy of  $\pm 10 \mu\text{g}$  after regeneration at 473 K at high vacuum for 12h. An oil diffusion pump coupled to a mechanical vacuum pump (Edward type Diffustak 63/150M) provided vacuum to  $10^{-3} \text{ Pa}$ . The pressure was monitored by a convector gauge with a vacuum gauge controller (Granville- Philips type 307). The volume of the adsorbent cell was determined by expansion of helium gas. <Figure 1>

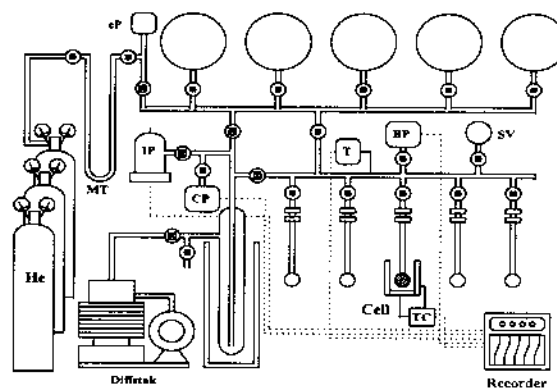

(BP) Baratron Transducer (CP) Convector Gauge  
(cP) Compound Gauge (IP) Ion Gauge  
(MT) Moisture Trap (SV) Standard Volume  
(T) Thermocouple (TC) Temperature Controller

Figure 1. The static volumetric equilibrium apparatus.

### Adsorption dynamics.

A fixed bed adsorption unit in Figure 2 was examined to study adsorption dynamics in column packed with activated carbon fiber. The packing characteristics of adsorption column and properties of packed adsorbent are given in Table 1. < Table 1>

The nitrogen gas line was divided into five branches. One was for pure nitrogen gas as a carrier and the others were connected into four branched solvent saturators.

Table 1. Packing characteristics and properties of column used

Adsorbent	Nano-10
Particle density, $\text{kg} \cdot \text{m}^{-3}$	1.6
Bulk density, $\text{kg} \cdot \text{m}^{-3}$	0.136
Particle porosity	0.21
Bed void fraction	0.35
Column diameter, cm	1.7
Column length, cm	3.1

In this method, a part of nitrogen gas was fed to a saturator to load objective solvent and was mixed with the pure nitrogen gas stream. In order to ensure homogeneous mixing of solvent vapors with pure nitrogen gas stream, a static in-line mixer was installed at the inlet section of the adsorption column. On condition that a concentration and a flow rate are fixed at constant temperature, the solvents-laden gas stream was fed to a fixed-bed adsorption column. The sets of experiment system that is given the variables as an inlet concentration and a flow rate are tabulated in Table 2. During the adsorption, the concentration history at the exit of the adsorption bed was monitored by a gas chromatograph (Hewlett Packard type 5890 series II) equipped with a flame ionization detector and helium as the carrier gas. A packed column (Supelco type Bentone 34) was used to analyze the volatile organic vapors in a nitrogen flow. <Figure 2, Table 2>

Table 2. Experimental condition of isothermal fixed bed runs

Run No.	Toluene		Trichloroethylene	
	Feed Ci	u	Feed Ci	u
	ppm	$\text{m} \cdot \text{s}^{-1}$	ppm	$\text{m} \cdot \text{s}^{-1}$
Run #1	1146.48	0.15	1422.07	0.20
Run #2	1087.25	0.25	1414.18	0.32
Run #3	1082.25	0.35	1410.37	0.42
Run #4	2104.19	0.16	2427.94	0.21
Run #5	2095.06	0.25	2426.62	0.30
Run #6	2091.03	0.35	2380.48	0.41
Run #7	3145.51	0.15	3360.58	0.20
Run #8	3103.30	0.25	3384.29	0.31
Run #9	3085.11	0.35	3395.50	0.42

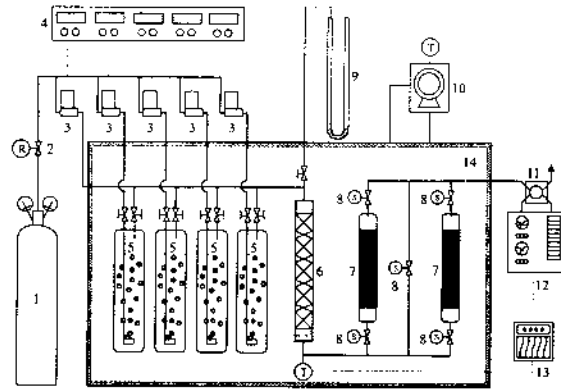

1. Nitrogen gas
2. Inlet pressure regulation valve
3. Mass flow controller
4. Control box
5. Solvent evaporator
6. In-line static mixer
7. Adsorption column
8. Air actuated ball valve
9. Pressure manometer
10. Refrigerating water circulator
11. Automatic 6-port valve
12. Gas chromatograph
13. Chart recorder
14. Water bath

Figure 2. Isothermal fixed bed equipment.

## RESULTS AND DISCUSSION

### Adsorption equilibria.

The adsorption isotherms of toluene and trichloroethylene onto activated carbon fiber were obtained at temperatures of 298, 323, and 348 K and pressures up to 3 kPa for toluene and 6 kPa for trichloroethylene, respectively. As shown in Figures 3 and 4, the experimental data are indicated as symbols and fitted isotherms used the Toth equation as solid lines. <Figure 3, 4>

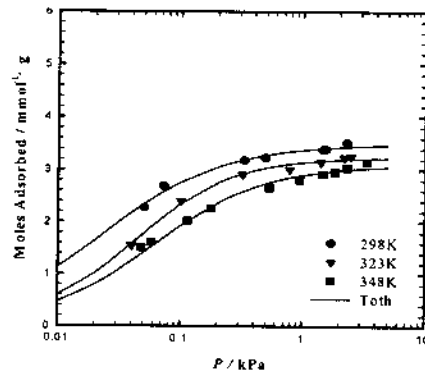

Figure 3. Equilibrium isotherm of toluene onto activated carbon fiber

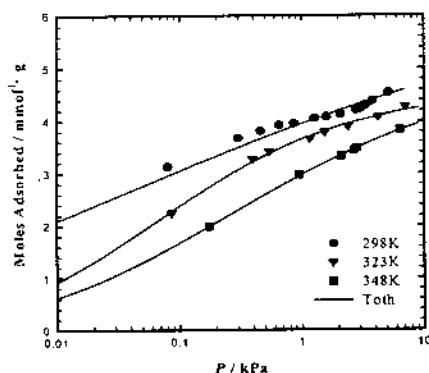

Figure 4. Equilibrium isotherm of trichloroethylene onto activated carbon fiber

Toth

$$N = \frac{mP}{(b + P^t)^{1/t}} \quad (1)$$

The average deviation parameter ( $D$ ) was employed to compare the correlation results with the experimental data.

$$D = \frac{1}{k} \sum_i^k \left| \frac{N_i^{obs} - N_i^{cal}}{N_i^{obs}} \right|, \quad k = \text{the number of data} \quad (2)$$

Among the several isotherm models: Langmuir, Sips, Toth, UNILAN<sup>7)</sup>, Dubinin-Astokov (D-A), and Dubinin-Radushkevich (D-R)<sup>8)</sup>, because the correlation by the Toth equation obtained the minimum value of the average deviation parameter ( $D$ ) as can be seen in Table 3, the Toth equation was applied. Isotherm parameters of the Toth equation are tabulated in Table 4. <Table 3, 4>

Table 3. Average deviation parameters ( $D$ ) for each isotherm model

	Toluene, DN (%)			Trichloroethylene, DN (%)		
	298K	323K	348K	298K	323K	348K
Langmuir	1.84	1.72	2.35	2.71	3.00	2.78
Sips	1.82	1.72	0.83	2.21	1.21	0.47
Toth	1.80	1.75	0.78	2.02	1.16	0.42
UNILAN	3.76	6.78	2.48	2.73	3.46	3.45
D-A	2.03	1.65	0.77	2.36	1.26	0.52
D-R	2.48	5.76	2.90	2.73	1.99	0.64

Table 4. Toth equation parameters for toluene and trichloroethylene onto activated carbon fiber

Adsorbate	Temperatur	$m$	$b$	$t$
	K			
Toluene	298	3.507	0.033	0.849
	323	3.240	0.035	0.756
	348	3.292	0.094	0.620
Trichloroethylene	298	4.595	0.070	0.532
	323	4.595	0.123	0.505
	348	5.079	0.216	0.365

In Eq 1,  $N$  is the specific amount adsorbed,  $P$  is the equilibrium pressure,  $m$  is the maximum adsorbed amount with respect to the complete monolayer coverage,  $b$  is related to the adsorption affinity, and  $t$  refers to the heterogeneity of the system, when  $t=1$ ; the system is homogenous<sup>7)</sup>.

At an isothermal fixed bed unit, if the adsorbable species exist at the trace level and the flow rate and temperature are constant during the experiment, one can also calculate the amount adsorbed at a specific equilibrium concentration (inlet concentration) as follows :

$$N = \frac{FC_0}{w} \left[ t_s - \int_0^{t_s} \frac{C}{C_0} dt \right] \quad (3)$$

where  $t_s$  is saturation time, which is the elapsed time when all  $C$  reach  $C_0$  at the exit of the column. In Figure 5, it can be compared the equilibrium data obtained by static volumetric method with the data obtained from the breakthrough data analysis. In this figure, the closed symbols indicate the data obtained by the static volumetric method, the open symbols indicate the data obtained from the breakthrough data analysis, and the prediction result using the Toth isotherm model is represented by the solid line, respectively. As can be seen, the qualitative agreements of two different experimental techniques are found in the

figure. <Figure 5>

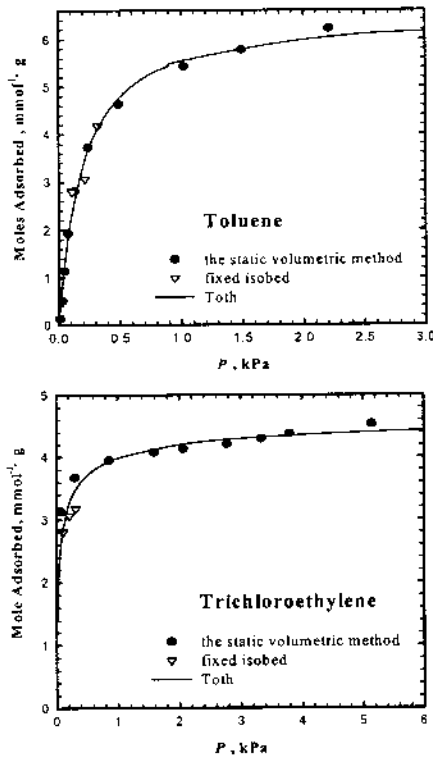

Figure 5. Comparison of equilibrium isotherms onto Nano-10 at 298 K

**Dynamics in column**

The breakthrough curves for toluene and trichloroethylene in an isothermal condition of 298 K were presented in Figure 6 and Figure 7. As a rule, activated carbon fiber has much steeper breakthrough curve than that of activated carbon or other adsorbent in that adsorbate vapors in an activated carbon fiber with only micropores reach the adsorption sites through micropores without the additional diffusion resistance of meso- or macropores, and it was required for very short time reaching  $C / C_0 = 1$ . Breakthrough curves of toluene and trichloroethylene reflected the effect of feed concentration and flow rate of solvent-laden gas. It is obvious that high feed concentration also makes steeper breakthrough than low feed concentration.

This is due to the fact that the higher bulk concentration can make the greater concentration driving force between bulk and solid phase<sup>9-10</sup>. And, when the feed concentration is lower, a longer time is required for reaching the column saturation.

<Figure 6, 7>

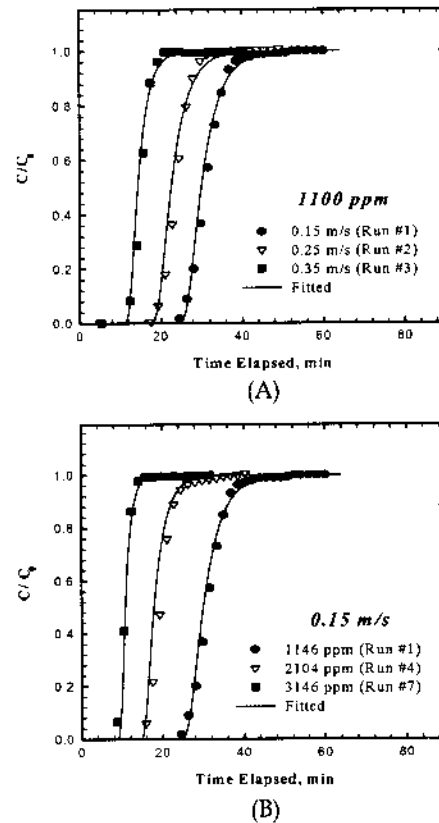

Figure 6. Breakthrough curves of toluene: (A) effect of linear velocity under feed concentration, (B) effect of feed concentration under constant linear velocity.

To represent the adsorption dynamics in column, the linear driving force (LDF) approximation model for overall mass transfer coefficient was applied. It is considered that this system is an isothermal and plug-flow<sup>10</sup>. The linear driving force model approximates the solution of Fickian diffusion inside a spherical particle. This expression assumes that the mass transfer rate of adsorption is

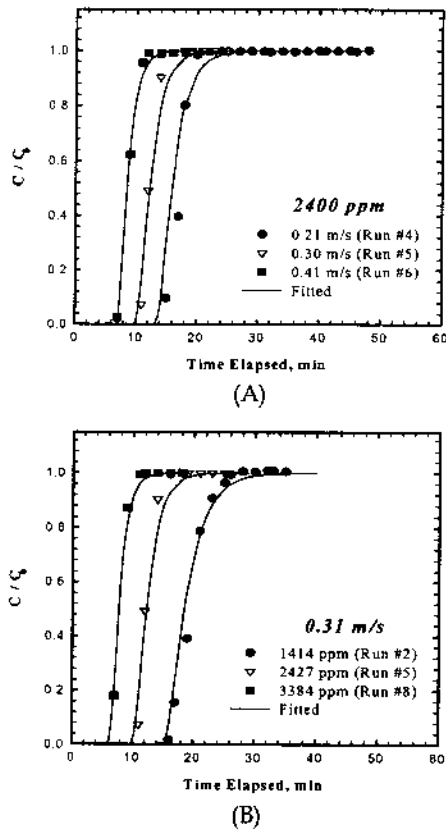

Figure 7. Breakthrough curves of trichloroethylene: (A) effect of linear velocity under constant feed concentration, (B) effect of feed concentration under constant linear velocity.

proportional to the differences between the equilibrium concentration and the bulk concentration of the component. The linear driving force model for gas adsorption kinetics is frequently and successfully used for analysis of column dynamics because it is simple, analytic, and physically consistent<sup>11</sup>. We assumed that the velocity of the gas in column is constant, and radial temperature, concentration and velocity gradients within the bed are negligible in this model. With the ideal gas-law assumption, the set of equations for this work is as follows:

**Mass balance for component i :**

$$-D_L \frac{\partial^2 y_i}{\partial z^2} + \frac{\partial y_i}{\partial z} + \frac{\partial y_i}{\partial t} + \frac{RT}{P} + \frac{1-\epsilon}{\epsilon} \rho_p \frac{\partial n_i}{\partial t} = 0 \quad (4)$$

**Mass transfer rates :**

$$\partial n_i + \partial t = k_i (n_i^0 - n_i) \quad (5)$$

**Boundary condition at  $z=0$  and  $z=L$  and for  $t>0$  :**

$$D_L \frac{\partial y_i}{\partial z} \Big|_{z=0} = -u (y_i \Big|_{z=0^-} - y_i \Big|_{z=0^+}) \quad (6)$$

$$\frac{\partial y_i}{\partial z} \Big|_{z=L} = 0 \quad (7)$$

Although the model equation included the axial dispersion coefficient ( $D_L$ ), plug flow was approximated by assigning a very large value to the Peclet number ( $uL/D_L$ ). This is because the effect of axial dispersion is quite negligible in a small column and the model with the second derivatives can give more stable numerical results.

The preceding set of partial differential equations (PDEs) was written in dimensionless form and the solution was numerically obtained. The PDEs were first reduced to a set of ordinary differential equations (ODEs) by the method of lines (MOL) technique, and the derived ODEs were integrated with respect to time by using the subroutine DIVPAG in IMSL. By using a mathematical model to optimize the breakthrough data of toluene and trichloroethylene with fitted results, the values of the overall mass transfer coefficients were calculated for each experiment condition<sup>12-13</sup>. Adapted a nonlinear regression technique, the results of calculation were given the following relationships :

$$k_{Toluene} = 0.091 \times [P]^{0.920} [u]^{0.564} \quad (8)$$

$$k_{Trichloroethylene} = 0.0712 \times [P]^{0.769} [u]^{0.671} \quad (9)$$

In Eqns. (8) and (9),  $k$  is overall mass transfer rate coefficient,  $P$  is partial pressure (in kPa), and  $u$  is interstitial bulk fluid velocity (in m/s) in column. Because of the lack of experimental data, the

correlation can only be available in the experimental range, the partial pressure of 0.11 to 0.35 kPa for toluene and trichloroethylene, and the interstitial bulk fluid velocity of 0.22 to 0.46 m/s.

## CONCLUSIONS

In this study, the adsorption equilibrium data of toluene and trichloroethylene onto activated carbon fiber, Nano-10, were obtained at temperatures of 298, 323, and 348 K and pressures up to 3 kPa for toluene and 6 kPa for trichloroethylene. The Toth equation gives the results in remarkable agreement compared with the experiment data. And, to represent the dynamics in adsorption column, a mathematical model based on linear driving force approximation was employed. By optimizing the breakthrough curves for toluene and trichloroethylene with a dynamic model, the overall mass transfer coefficient can be represented by a function of the partial pressure for each adsorbate and interstitial bulk fluid velocities of gas flow.

## REFERENCES

1. Faisal I. Khan and Aloke Kr. Ghoshal: *J. of Loss Prevention in the Process Industries*, 13, 527-545 (2000)
2. Blocki, S. W.: *Environ. Prog.*, 226-234 (1993)
3. Katsumi, K.: *J. Membrane Sci.*, 96, 59-89 (1994)
4. Takeshi, Y. and Shigeta, A.: *Sep. Sci. Technol.*, 3, 46-52 (1993)
5. White, R. F. and S. P. Procter: *Lancet*, 349, 1239-1243 (1987)
6. Kim, Y. M.: Patent No. 10-1999-0047363, Korea (1999)
7. Valenzuela, D. P. and Mayers, A. L.: "Adsorption of Equilibrium Data Handbook", Prentice Hall (1998)
8. Duong, D.D.: "Adsorption Analysis Equilibrium and Kinetics", Imperial College Press, London (1982)
9. Petrovic, L. J. and Thodos, G.: *Ind. Eng. Chem. Fund.*, 7, 274-280 (1968)
10. Yun, J. H., Choi, D. K. and Kim, S. H.: *AIChE*, 45 (4), 751-760 (1990)
11. S. Sircar and J. R. Hufton: *Adsorption*, 6, 137-147 (2000)
12. Smith, J. M.: "Chemical Engineering Kinetics", McGraw-Hill (1981)
13. Schork, J. M. and Fair, J. R.: *Ind. Eng. Chem. Res.*, 27, 457-469 (1988)